



DIN Rail

D-1SHU-DC

DIN Rail D-4SHU to H-Bridge adapter.

Technical data

Relay contact specs: 5 A @ 30 VDC / $\cos \Phi = 1$
 Ingress protection IP IP20

Description

The D-1SHU-DC is a DIN rail module to be intercalated between a D-4SHU output and 24 VDC shutter motors.

It requires an external 24 VDC power supply for the DC-motors.

The D-1SHU-DC is equipped with 4 non-latching relays in H-bridge configuration allowing the control of DC-motors by polarity inversion.

The power supply of the module is independent of the loads to be switched.

Applications

Command for shutters, sunscreens, blinds, curtains, projection screens, black-outs and other Open/Close 24 VDC equipment in homes, shops, hospitals, clinics and hotels.

Installation

The D-1SHU-DC is made for DIN rail mounting, occupying 1 module of 17.5 mm.

Features

5 A relay outputs

Actuator for 1x shutter with DC motor

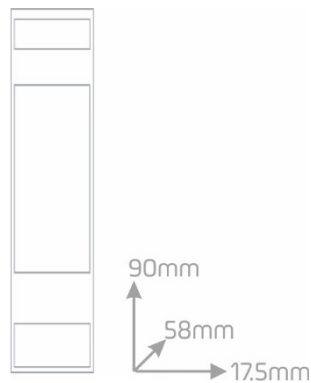

Danger - Electric Shock Risk!

Switch off the power before any intervention.

Handling by qualified and authorized persons only.

Subject to change without notice



DIN Rail D-1SHU-DC

DIN Rail D-4SHU to H-Bridge adapter.

Connection Diagram:

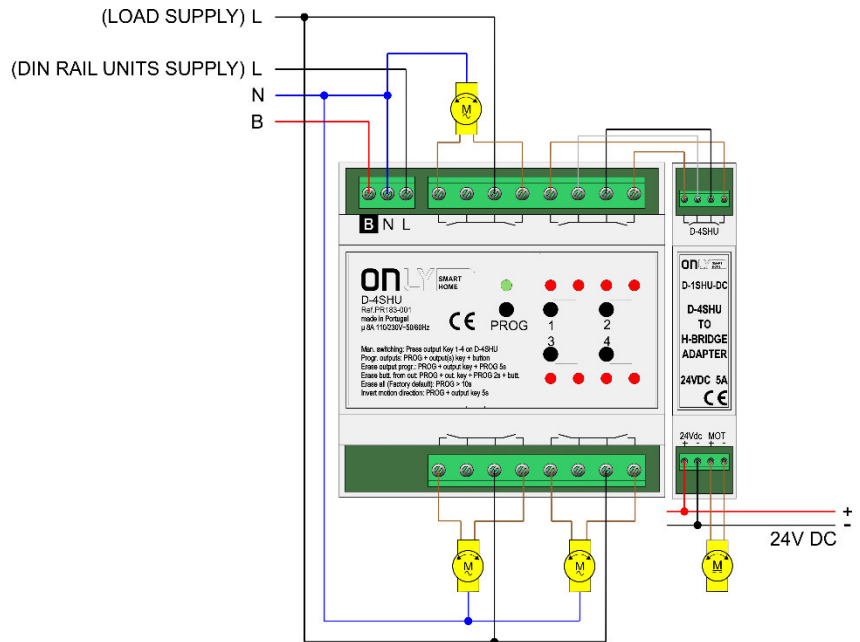

Danger - Electric Shock Risk!
 Switch off the power before any intervention.
 Handling by qualified and authorized persons only.

Subject to change without notice