**In Wall****C-1SHU**

1 channel 230 V~ shutter actuator 8 A

Technical data

Power supply	230 V ~ 50 Hz
Consumption	< 1.5 W
Maximum load current	8A cos Φ =1
Ingress protection IP	IP20

Description

The C-1SHU is a 230 V~ shutter actuator that can receive any touch panel OT-_S.

Applications

Command for shutters, sunscreens, blinds, curtains, projection screens and black-outs of 230 V~ in homes, shops, hospitals, clinics and hotels.

Installation

The C-1SHU is mounted in a deep flush-mounting box (60 mm), where the OT-_S touch panel will be attached.

Features

8 A relay outputs

Local operation even without BUS connection

Status indication by LED

WAGO push-wire terminal connections with derivation

Open and close time independently configured

Up to 28 buttons can be stored in the internal non-volatile memory

Operation modes: Toggle, Up, Down, Timer, Delay and Scenario, depending on the received command

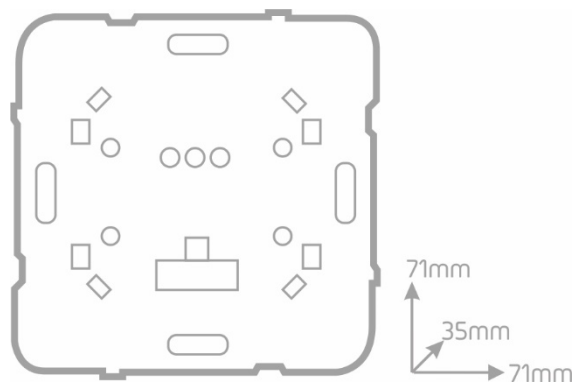

Danger - Electric Shock Risk!

Switch off the power before any intervention.

Handling by qualified and authorized persons only.

Subject to change without notice

Enancer Electrónica, Lda

Rua Max Grundig, 9
4705-820 Braga Portugal
Tel: +351 253 221 484
info@only-smartbuildings.com

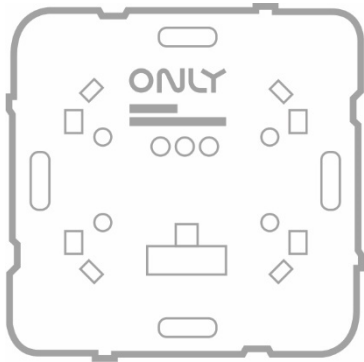

In Wall
C-1SHU

1 channel 230 W~ shutter actuator 8 A

Connection Diagram:

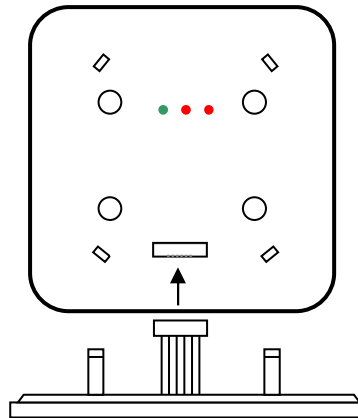
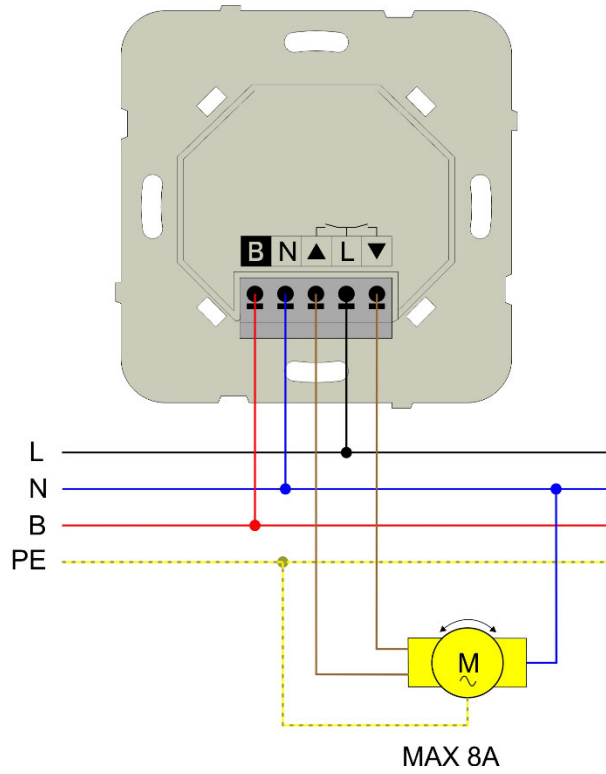

Danger - Electric Shock Risk!
 Switch off the power before any intervention.
 Handling by qualified and authorized persons only.

Subject to change without notice