

In Wall

C-1DIM

1 channel phase-cut R, C dimming actuator 300 W

Technical data

Power supply	110/230 V ~ 50/60 Hz
Consumption	< 0.5 W
Maximum load	300 W
Ingress protection IP	IP20

Description

The C-1DIM is a dimmer for resistive or capacitive loads of 300 W and that can receive any touch panel OT-_S_.

This allows, the light dimming of incandescent or halogen lamps (even when associated to electronic transformers) or other lamps with dimmable electronic drivers.

Applications

Intensity control of the incandescent and halogen lights (with or without electronic transformer) in homes, shops, hospitals, clinics and hotels.

Installation

The C-1DIM is mounted in a deep flush-mounting box (60 mm), where the OT-_S_ touch panel will be attached.

Features

Dimming 0 to 100% gradually increasing

Local operation even without BUS connection

Status indication by LED

Automatic memory of last selected light level

Memorizing different values for various scenarios

WAGO push-wire terminal connections with derivation

Up to 28 buttons can be stored in the internal non-volatile memory.

Operation modes: Toggle, Up, Down, Timer, Delay and Scenario, depending on the received command

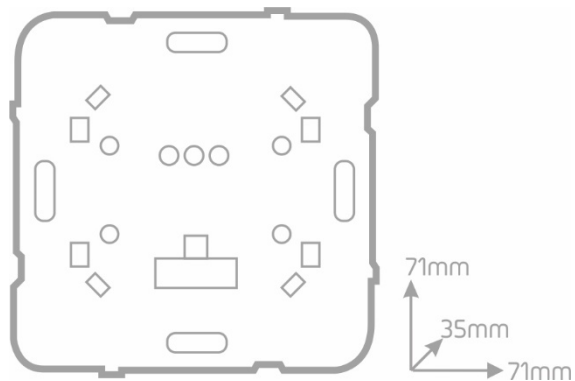

Note:

This dimmer cannot be used with ferromagnetic transformers.



Danger - Electric Shock Risk!

Switch off the power before any intervention.

Handling by qualified and authorized persons only.

Subject to change without notice

Enancer Electrónica, Lda

Rua Max Grundig, 9
4705-820 Braga Portugal
Tel: +351 253 221 484
info@only-smartbuildings.com

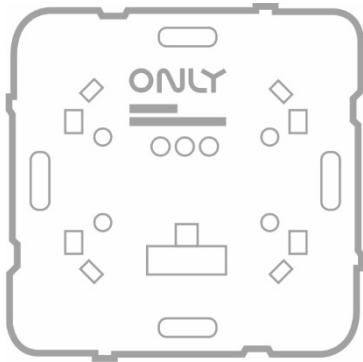

In Wall C-1DIM

1 channel phase-cut R, C dimming actuator 300 W

Connection Diagram:

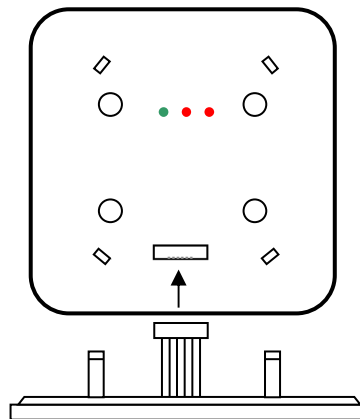
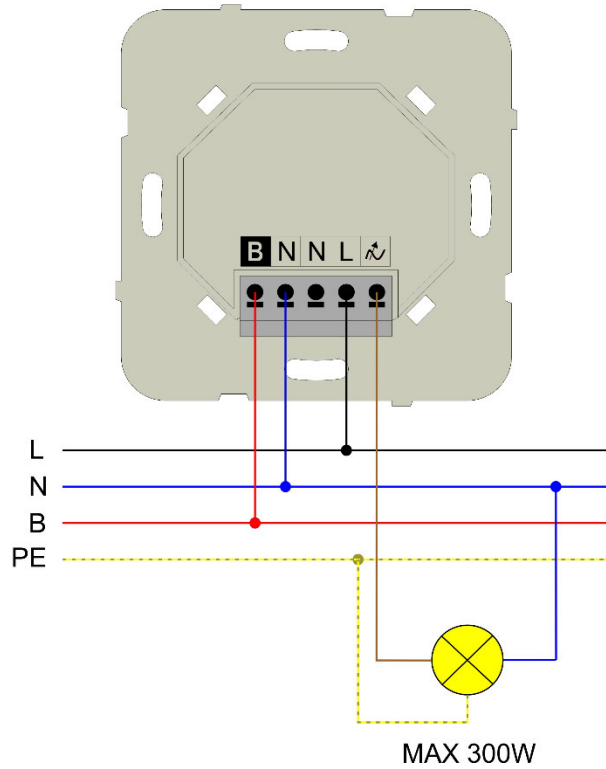

Danger - Electric Shock Risk!
Switch off the power before any intervention.
Handling by qualified and authorized persons only.

Subject to change without notice